

DESIGN
MANUFACTURE
SUPPLY

WORLDWIDE DIAMOND
TOOLING SOLUTIONS



INTRODUCTION



CUTTING



DRILLING



PROFILING



GRINDING



POLISHING



HAND MACHINES

THE COMPANY

D.K. Holdings Limited has been manufacturing diamond tools and associated products since 1959. We have developed a unique expertise in producing and supplying diamond tools specifically for the stone industry.

ISO 9001 QUALITY STANDARD

Our products are made to the highest quality standards and we are accredited with the approved quality management system BS EN ISO 9001 : 2015 for the manufacture and supply of our products.

DIAMOND TOOLS

Electroplated, electroformed, metal bonded and resin bonded diamond tools are used on various materials because of very fast clean cutting, long life, versatility of design and relatively low cost.

REPLATE & REDRESS SERVICE

We are able to replate and or redress at very competitive prices many products of our own manufacture and also of other manufacturers which improves performance of the tools and saves money!

STOCK & SPECIAL TOOLS

A large range of the most popular products are held in stock at our Staplehurst factory for immediate despatch. Special tools can be designed and manufactured to meet your specific requirements on a short lead time.

Our Engineers can test and advise on the best tooling required for specific materials.

VISIT OUR FACTORY

We are happy to invite you to visit our UK factory located opposite Staplehurst Railway Station, which is on the main railway line just 60 minutes from London's Charing Cross Station.

ADDRESS: Station Approach, Staplehurst, Kent TN12 0QN, UK
TELEPHONE: +44 (0)1580 891662
FAX: +44 (0)1580 892724
E-MAIL: info@dk-holdings.co.uk
Website: www.dk-holdings.co.uk

INFORMATION

The information in this catalogue is given as a guide only and we reserve the right to alter, amend and delete prices, specifications and product availability without prior notice.



@DK_Holdings



DK Holdings Limited

PRODUCT INDEX

	Page No.
A	
Abrasive Dressing Block	6
ACCESSORIES	33-36
Adaptors	7, 9, 12, 17, 19, 21, 25, 28
Air Tools	37-38
Aluminium Backup Pad	25
Arix Blue Sabre Blades	3
Arix Silent Centre Blade	1
AS100 Angle Saw	38
AS125 Angle Saw	38
B	
Bandsaws Blades	6
Bands, Expanding Rubber Mandrel	21
Belts	21, 28
Black Knight Segmented Blade	3
Black Turbo Continuous Rim Blade	4
Blades	1-6
Burrs, Vacuum Brazed Diamond Profile	13
C	
Ceramica Diamond Resin Discs & Backup Pads	23, 25
Ceramica Resin Drums	29
Chevron Drum, Mini & Drum Adaptor	29
Chevron Resin Drums	28
Chevron Drums for CNC Machines	28
Chevron Belts, Rubber Drum & Adaptor	28
Chevron Dressing Bar	28
Clear Cut Silent Centre Blades	2
CNC TOOLING	8, 11, 13-14, 17-18, 28, 30, 32
- Drilling	8
- Profiling	11, 13-14
- Grinding	17-18
- Polishing	28, 30, 32
CNC Fluting Wheels	32
Cont'tal - 22.2mm Adap for ProGem & Profile Routers	12
Continuous Rim Blades	4-5
Core Drills	7-8

	Page No.
C (cont'd)	
Cup Wheels	15
Cushioned Drums & Adaptor	17
CUTTING	1-6
Cyclone Flat Wheels	16
D	
Dekton & Neolith Blades	4
Dewalt Router	37
Dia-Board Discs, Electroplated	15
Dia-Dot 130 Edging Wheels	26
Dia-Dot 100 Solid Discs & Disc Adaptors	25
Dia-Dry Discs	16
Dia-Gem Flexible QRS Discs & Backup Pads	25
Dia-Grind Cup Wheels	16
Dia-Met Hand Pads	20
Dia-Rap Radial Arm Polishing System	27
Dia-Sol Discs & Disc Adaptors	25
Diagrit Water Chucks	9
Diamond Profile Burrs, Vacuum Brazed	13
Diamond Sharp Block	22
Diamond Resin Discs & Wheels	23-26, 28-29
Diamond Blades	1-6
Diamond Cup Wheels	15-16
Diana T30 Flat Dish Wheel	16
DK Arix Silent Centre Blades	1
Dressing Bar for (Chevron)	28
Dressing Block, For Flute Polishing Wheels	32
DRILLING	7-9
Drills	7-9
Drums	17, 21, 28-29
Dry Cut Blades	3-6
Dry Grinding Disc	15-16
Dry Polishing Discs	23
E	
Edge Polishing Discs & Gaskets	26
Electric Machines	37
Electroflex Diamond Products	19-22
Electroflex Discs	19

PRODUCT INDEX

	Page No.		Page No.
E (cont'd)		I-J-K	
Electroflex Pads	20, 22	Inox VB Profile & Chamfer Wheels	13
Electroflex Vanity Drums	21	Kwik-Cut CNC Drills	8
Electroflex Belts	21	Kwik-Flex Flexible Discs & Backup Pads	24-25
Electroflex Hand Files	22	Kwik-Flute CNC MB Routers	13
Electroflex Hand Pads	20		
Electroflex Sheets	22	L-M-N	
Electroflex Profile Hand Pads	20	Line Breakers	18
Electroplated Continuous Rim Blades	5	Mandrels, Expanding Rubber	21
Electroplated Cushioned Drum	17	Marble Blades	1-2, 5
Emperor Edge Polishing Wheels	26	Marble Polishing Discs	19, 23, 25-27
Expanding Rubber Drums	21, 28	Metal Bond Blades	1-4, 6
Expanding Rubber Mandrels	21	Metal Bond Horizontal Blades	1
		Metal Bond CNC Mini Grinding Drums	17
F		Milling Wheels (Metal Bond for Granite)	18
Fein Multi-Talent Oscillating	37	Mini Chevron Drums & Adaptor	29
Felt Pads	35	Multi-Cut Core Drills Metal Bond Segmented & Crowned	8
Flex Electrica 110v Wet & Dry Polishers	37	Multi-Cut Core Drills for Pop Up Sockets	8
Flexible Diamond Belts	21	Multi-Cut Power Blade	2
Flexible Diamond Discs	19		
Flutemaster Flute Grinding/Polishing System	31	O-P	
Flute Grinding & Polishing Wheels - 2 Stage	32	Oma to 22.2mm Adaptor for Pro-Gem & Profile Routers	12
Flute Polishing Wheels (Resin) & Dressing Block	32	Orbital Sander Pads	22
Flute Polishing System	31	Pads	20, 22
Flute Wheels (Seelbach Machine)	32	Panther Flexible Resin Discs & Backup Pads	24-25
Fluting Wheels (Electroplated)	10	Parallel Routers (Dewalt Routing Machine)	12
		Parallel Routers Metal Bond & Vacuum Brazed	12, 14
G		Pneumatic Tools	37-38
Gaskets for Edging Wheels	26	Polishing Compound	35
Granite Blades	1-4, 6	POLISHING	19-32
Granite Drums, Chevrons	28-29	Polishing Discs	19, 23-27
Granite Drill Adaptors for use with Water Chucks	9	President Edge Polishing Wheels	26
GRINDING	18-18	Pro-Cut Vanity Bowl Crowns & Routers	14
GS Drums	17	Pro-Gem Profiling & Polishing System	11
		Profile Burrs, Vacuum Brazed	13
H		Profile Routers for Marble & Slate	12
Hand Files	22	Profile Wheels	10-13
HAND MACHINES	37-38	Profile Routers (Dewalt Router)	12
Hand Pads	20	Profile Machine	37
Hercules MB Cutting/Grinding Blade	6	Profile Routers for Granite	12

PRODUCT INDEX

	Page No.		Page No.
O-P (cont'd)		S (cont'd)	
PROFILING	10-14	Stone Care Products	34-35
Pro-Edge CNC Profile Polishing System	11	Stone Flooring	38, 39
Puma Flexible Resin Discs & Backup Pads	24-25	Stone Repair Kit	33
Pyramid Vanity Blades	5	Strip & Replate Service	39
Q-R		Supreme Flexible Discs & Backup Pads	23, 25
QRS Converter, Radial Arm	27	T	
Quick Q-6R Pneumatic Polisher	37	Template Material	36
Radial Arm Polishing Discs	27	Three Step Polishing Discs & Backup Pads	23, 25
Rapier Vacuum Brazed Diamond Discs	15	Tile Blades, Continuous Rim Metal Bond	4
Recess Drainer System	11	Tile (Ceramic) Drilling Kit	36
Regrind & Reprofile Service	39	Titan Dry Grind Discs	16
Reinforcing Bar, GRP	36	Translucent Template Material	36
Repairlux Repair Kit	33	Trojan, Vacuum Brazed Diamond Discs	15
Rhino Radial Arm Polishing System	27	Twister Radial Arm Polishing System	27
Rubber Expanding Drum	21	Typhoon & Typhoon Max Pads	39
Rubber Drum Adaptors	21	U-V	
S		Ultra Mini CNC Polishing Routers	30
3 Step Polishing Discs	23	Under Chamfer Tool	18
Samurai Metal Bond Gulleted Blades	3	Vacuum Brazed Core Drills	7
Saws	1-6	Vacuum Brazed Drums	17
SD Milling Wheels	18	Vacuum Brazed Discs	15-16
SD CNC Grinding & Polishing System	11	Vacuum Brazed Router	14
Segmented Blades	1-3	Vanity Blades	5
Sharpening Block, Chisels & Knives	22	Vanity Drums & Drum Adaptor	21
Sheets Diamond Electroflex	22	Viking Discs, Vacuum Brazed	15
Silent Centre Gulleted Blade	1-2	W	
Snail-Lock Backup Pads	25-26	Water Chucks	9
Snail-Lock Cup Wheels	16	Wet Cut Blades	1-2, 4
Snail-Lock Discs	16m 25-26	Wet Polishing Discs	19, 23-57
Snail-Lock Spanner	26	Wet Polishers	37
Solid Granite Drills	9	X-Y-Z	
Solid Granite Drill Adaptors	9	Zenesis CNC Parallel Routers	14
Starlite Polishing Drums	29		
Starrett Adaptors	7		

CUTTING

Our large range of diamond saw blades has been carefully selected to give you a quality cut at the most economical price. Sizes available are from 100mm to 600mm and the most popular sizes are normally held in stock for immediate despatch.

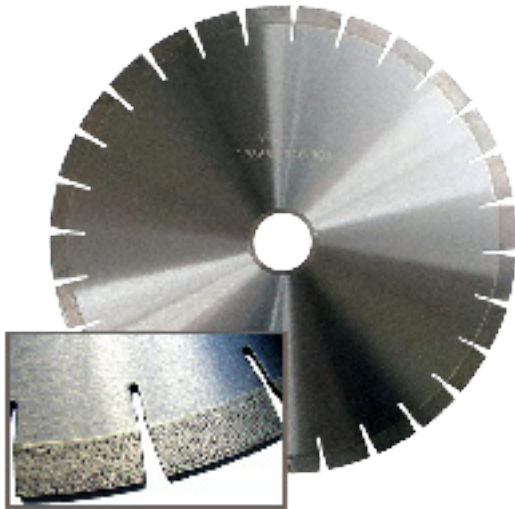

DK ARIX SILENT CENTRE BLADES

This silent centre blade has been specially developed to provide an improved cutting speed together with a clean cut and longer life.

WET GRANITE ENGINEERED STONE

FOR STANDARD POWERED MACHINES DIMENSIONS

Diameter 300mm - 600mm
Segment Height 16mm
Bore 60/50 or as required

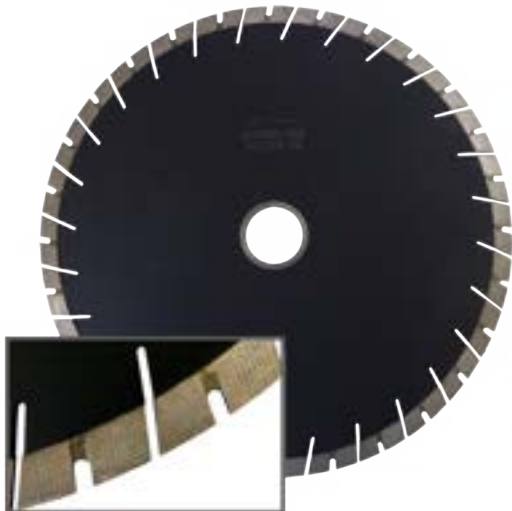

DK ARIX BLACK SILENT CENTRE BLADES

The DK Arix Black is of similar specification to the standard machine blade but with segments specifically formulated for use on lower powered machines.

WET GRANITE ENGINEERED STONE

FOR LOWER POWERED MACHINES (5-10HP) DIMENSIONS

Diameter 300mm - 600mm
Segment Height 16mm
Bore 60/50 or as required



METAL BOND HORIZONTAL BLADE

Specially developed for horizontal cutting. These metal bond blades are ideal for thinning down worktop edges and slot cutting. Various fittings available.

WET CNC GRANITE MARBLE ENGINEERED STONE

DIMENSIONS

Diameter 300mm
Segment Height 10mm
Segment Width 4.5mm
Bore Thibaut

NOTE

Other sizes available on request.

CLEAR CUT SILENT CENTRE BLADES

Premium, fast cutting laser welded segmented blades producing excellent results.

WET MARBLE SLATE

DIMENSIONS

Diameter 300mm - 600mm
Segment Height 7mm
Bore 60/50 or as required

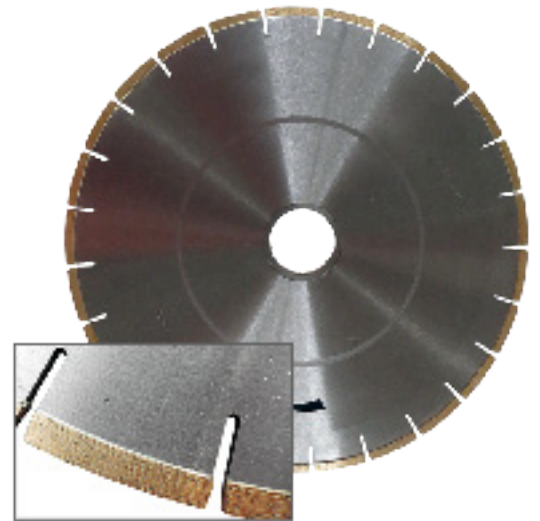

CLEAR CUT SILENT CENTRE BLADES

Premium fast cutting laser welded segmented blades producing excellent results.

WET GRANITE

DIMENSIONS

Diameter 300mm - 600mm
Segment Height 15mm
Bore 60/50 or as required

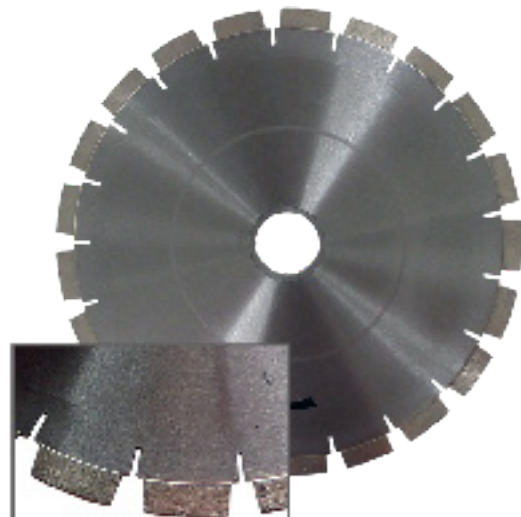

MULTI-CUT POWER BLADES

Specially designed blade for splinter free cutting. Supplied with silent centre core for noise reduction.

WET GRANITE MARBLE SLATE CONCRETE ENGINEERED STONE CRYSTAL STONE DEKTON/NEOLITH

SANDWICH CORE

DIMENSIONS

Diameter 254mm - 450mm
Segment Height 10mm
Bore As required



CUTTING



BLACK KNIGHT SEGMENTED BLADES

A unique metal bond diamond blade, combining a silent centre body for quieter running and reduced segments to enable fast clean cutting.

WET/DRY	GRANITE	STONE	ENGINEERED STONE
---------	---------	-------	------------------

DIMENSIONS

Diameter	125mm - 230mm
Segment Height	25mm
Bore/Fitting	22.2mm or M14

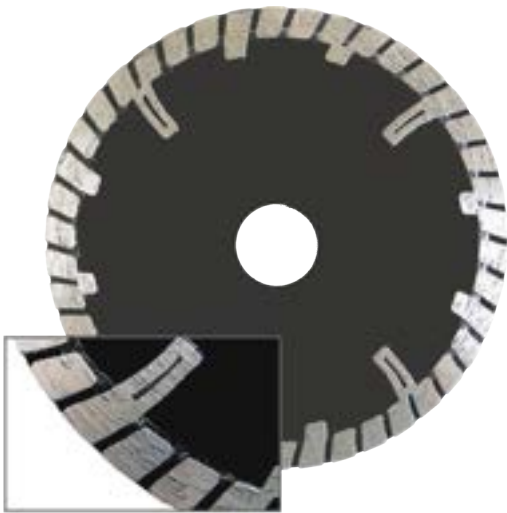

SAMURAI GULLETED BLADE

Economical diamond metal bond blade.

WET/DRY	GRANITE	STONE	ENGINEERED STONE
---------	---------	-------	------------------

DIMENSIONS

Diameter	125mm
Segment Height	23.5mm
Bore	22.2mm



ARIX BLUE SABRE BLADES

This hybrid of the successful Blue Sabre Blade now has a new Arix style segment to give a fast cutting action together with extended life.

WET/DRY	GRANITE	ENGINEERED STONE	SANDSTONE
---------	---------	------------------	-----------

DIMENSIONS

Diameter	115mm - 230mm
Segment Height	12mm
Bore	22.2mm & M14

BLACK TURBO CONTINUOUS RIM BLADE

This metal bond diamond blade is a cost effective way of very fast and clean cutting. The body contains extra cooling holes to prevent over heating.

WET/DRY GRANITE

DIMENSIONS

Diameter 125mm
Segment Height 8.5mm
Bore 22.2mm



TILE BLADES

Continuous rim metal bond diamond tile cutting blades are designed for fast and free cutting with minimal chipping.

WET/DRY PORCELAIN

DIMENSIONS

Diameter 80mm - 250mm
Segment Height 4.5mm
Bore 16mm & 22.2mm



DN BLADES

Specially designed, for cutting Dekton & Neolith type material.

WET

CERAMIC
GLASS

CRYSTAL
STONE

DEKTON/
NEOLITH

SANDWICH CORE

DIMENSIONS

Diameter 115mm - 230mm
Width 1.6mm
Bore/Fitting 22.2mm & M14



CUTTING

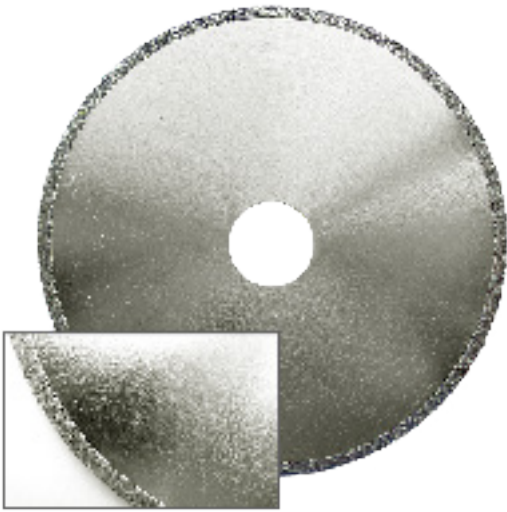

ELECTROPLATED CONTINUOUS RIM BLADES

High quality electroplated diamond blade. Grade 44/60.

WET/DRY MARBLE SLATE

DIMENSIONS

Diameter 100mm - 125mm
Bore 16mm & 22.2mm

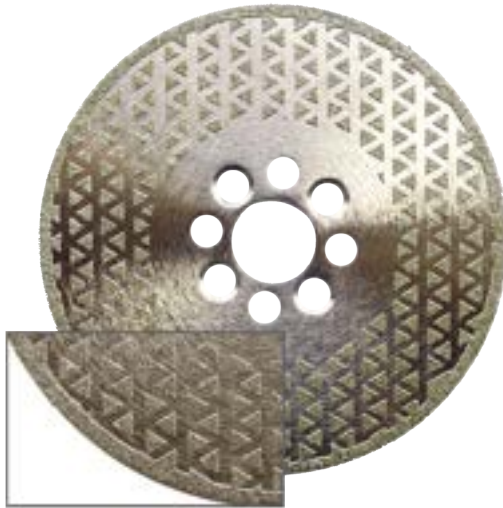

PYRAMID VANITY BLADES

A long lasting, hard wearing electroplated diamond cutting blade for professional use and ideal for cutting curves and apertures.

WET/DRY MARBLE SLATE

DIMENSIONS

PREMIUM

Coated Double Sided
Diameter 100mm - 125mm
Bore 16mm & 22.2mm

STANDARD

Coated Double Sided
Diameter 125mm
Bore 22.2mm



PYRAMID M14 FLANGE VANITY BLADES

With double side electroplated diamond coating and M14 fitting; ideal for cutting straight, or curves and apertures.

WET/DRY MARBLE SLATE

DIMENSIONS

PREMIUM

Coated Double Sided
Diameter 125mm
Fitting M14

STANDARD

Coated Double Sided
Diameter 115mm - 230mm
Fitting M14

HERCULES SIDE GRINDING BLADE

Strong metal bond blade for cutting and grinding with side grinding capabilities. The Hercules cuts and grinds with ease due to the unique side and face diamond areas.

WET/DRY GRANITE SLATE

DIMENSIONS

Diameter 125mm
Segment Height 25mm
Fitting M14



ABRASIVE DRESSING BLOCK

Used to re-dress blades after glazing or clogging of the diamond segments. Suitable for blades and segmented core drills.

DIMENSIONS

Block Size 200mm x 50mm x 50mm



BANDSAWS

Continuous rim and gulleted electroplated diamond bandsaw blades, manufactured by DK Holdings to any size and to fit most machines.

WET MARBLE SLATE

DIMENSIONS

Blade Width 12mm, 19mm & 25mm

GRADES 36/44, 44/60, 60/85, 85/100, 100/120, 150/170 & 200/240



DRILLING

A wide selection of drills is available for both site and factory use when cutting holes in granite, marble, other natural stones and engineered material. Water chucks are available for heavy duty use.



CORE DRILLS - M14 FITTING

DK Metal Bond and Vacuum Brazed Diamond Core Drills with M14 fitting. The M14 fitting converts to Continental by means of the adaptor.



METAL BOND DIMENSIONS

Diameter 14mm - 35mm
Fitting M14

VACUUM BRAZED DIMENSIONS

Diameter 20mm - 35mm
Fitting M14

ADAPTOR - M14 FITTING CORE DRILLS

AVAILABLE TYPE

Adaptor Continental to M14



CORE DRILLS - STARRETT FITTING

Comprehensive range of diamond core drills with Starrett fitting includes metal bond and electroplated 36/44 diamond grit. Ideal for site work.



METAL BOND DIMENSIONS

Diameter 12mm - 50mm
Arbor (Ø12-14mm) A1, (Ø16mm-50mm) A2

ADAPTORS - STARRETT FITTING CORE DRILLS



ELECTROPLATED DIMENSIONS

Diameter 14mm - 51mm
Arbor (Ø14-30mm) A1, (Ø32mm-51mm) A2

AVAILABLE TYPES

Adaptors A1 to A2, A1, A2, Continental to A2,
Pilot Drill 6.5mm

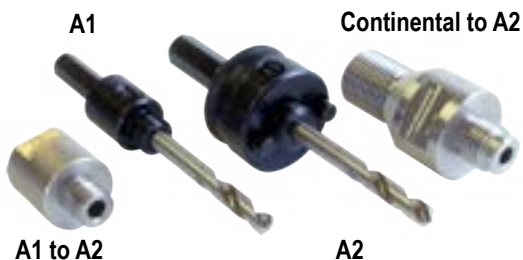

NOTE

Core Drills under Ø20mm need to be mounted on a MMP009 adaptor if using a water chuck.
Core Drills furnished without arbors unless specified.

KWIK CUT - CNC GRANITE DRILLS

Wet cutting granite drills for use on CNC and semi automatic machines cutting at a rate of 1mm per second and will cut up to 45mm thickness material.

WET	CNC	GRANITE	CRYSTAL STONE	DEKTOM/NEOLITH
-----	-----	---------	---------------	----------------

METAL BOND

DIMENSIONS

Diameters 14mm - 40mm
Fitting Continental 1/2" BSP



MULTI-CUT CORE DRILLS

Heavy duty metal bond diamond segmented or Multi-cut Core Drills for cutting clean holes.

WET	GRANITE	MARBLE	STONE	ENGINEERED STONE	SLATE
-----	---------	--------	-------	------------------	-------

METAL BOND

DIMENSIONS

Diameters O.D. 10mm - 162mm
I.D. 6mm - 154mm

Other diameters, shank fittings and open back ends are available as is our re-tip service subject to an acceptable condition of the tube, please enquire.



POP UP SOCKET MULTI-CUT CORE DRILLS

These EPU core drills are specifically designed for 'electrical pop up sockets' in counter/worktop islands.

WET	GRANITE	MARBLE	STONE	ENGINEERED STONE
-----	---------	--------	-------	------------------

METAL BOND

DIMENSIONS

Diameters 82mm - 102mm



DRILLING

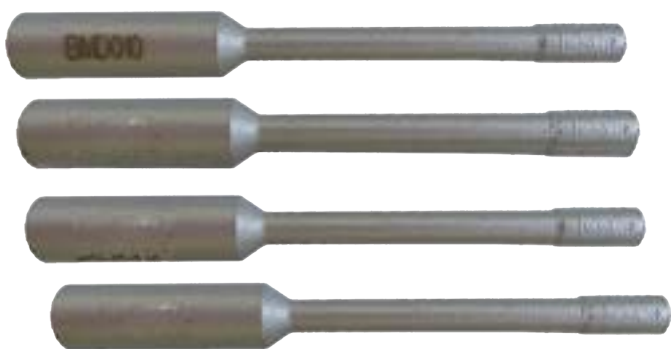

SOLID GRANITE DRILLS

Drills with a centre water feed for drilling holes with a fixed drilling machine. Adaptors are available to suit any water chuck fitting.

WET

GRANITE

STONE

ENGINEERED
STONE

METAL BOND

DIMENSIONS

Diameters 5mm - 15mm

Shank diameter 10mm

SOLID GRANITE DRILL ADAPTORS

AVAILABLE DRILL ADAPTORS

1. Continental 1/2" BSP : to accept 10mm dia. Shanks.
2. Diagrit Baby Water Chuck : to accept 10mm dia. Shanks.
3. Habit 1/2" BSF : to accept 10mm dia. Shanks.
4. Flex Machine - M14 to Solid Granite Drill Adaptor to accept 10mm diameter Shank.

DIAGRIT WATER CHUCKS

TYPE B - Water Chuck fits most popular pillar drills enabling water to feed through the centre of core drills.

Available with all types of shank fittings.

WATER CHUCK - TYPE B

Fittings Continental 1/2" BSP & Habit

Comes standard with JT6 to MT2 arbor and spanner.
Other Morse Tapers available on request.

BABY WATER CHUCK - A unique small water chuck is an easy answer to supplying water coolant to the working area when drilling holes with a hand held pistol drill.

The Baby Water Chuck comes complete with tap and pipe.
Also available Carbide drills - 1/4" diameter and A1 to A2 adaptor, please enquire.

Available with all types of shank fittings.

PROFILING

Diamond profile wheels for shaping are now very popular with our customers due to our ability to design and produce wheels up to 500mm diameter which can grind simple and intricate profiles into granite, marble, stone and engineered stone.

ELECTROPLATED FLUTING WHEELS

Rapid grinding of decorative flutes on the face of fireplaces, draining boards and columns. Electroplated Diamond Fluting Wheels are available in most grades and sizes. Please contact us with your requirements.

WET	GRANITE	STONE	CRYSTAL STONE	DEKTON/ NEOLITH
-----	---------	-------	------------------	--------------------

DIMENSIONS

Diameters 100mm - 400mm
Widths 10mm - 20mm



SPECIAL TOOLS & PROFILE WHEELS

Special tools and profile wheels for grinding simple and complex profiles can be designed and manufactured to meet customers' specific needs on a relatively short lead time.

Simply send a sketch, drawing or sample of the item required and we will quote you price and delivery.



We can STRIP, REPLATE & REDRESS or REGRIND & REPROFILE many products, whether purchased from DK or elsewhere at very competitive prices.

Please contact us to see how much can be saved when using this service.

Call: +44 (0)1580 891662

PROFILING

PRO-EDGE CNC PROFILE POLISHING SYSTEM

This Profile Polishing System grinds and polishes the edges of Granite and Marble achieving a professional high gloss finish. The seven stage system is available for the most popular shapes which includes ZS40, A30'5, V30 and F30. These profiles have central water feed with 35mm bore.



SD GRINDING & POLISHING SYSTEM

For grinding and polishing recessed draining boards in granite, offering a simple and effective system that quickly produces an excellent quality finish. Designed for use on semi automatic and CNC machines, the system produces superb results that most competitive systems are unable to achieve.



The eight stage system consists of a segmented Metal Bond wheel for rapid stock removal, coarse Electroplated wheels to grind side angle and calibrate draining board surface and five grades of Resin Bond wheels which produce a fantastic high quality polish to the angle and draining board surface. Resin grades require 2-4 passes depending on hardness of stone. All grades must be used wet.

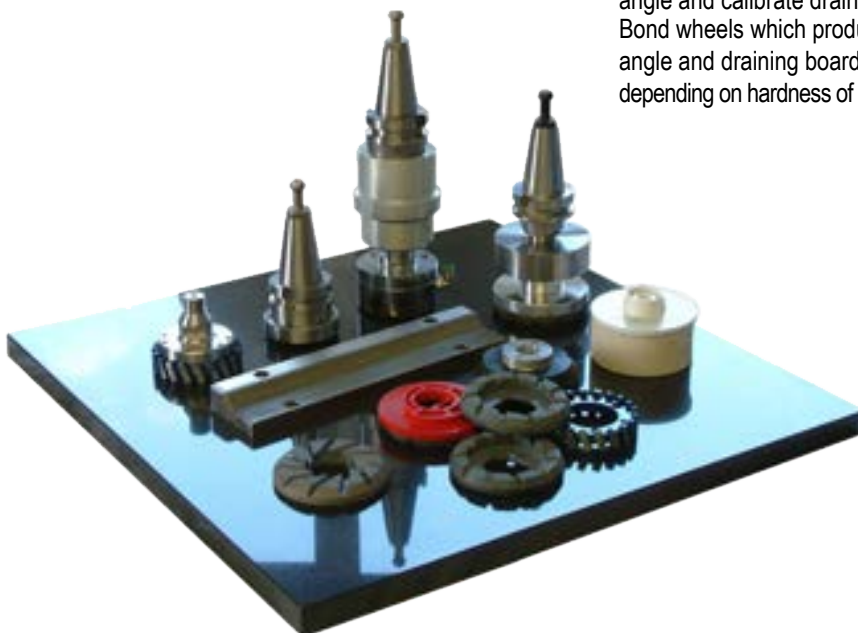

PROFILING

PRO-GEM HS PROFILE POLISHING SYSTEM

The Pro-Gem HS wheels have been specially designed for use on portable routing and semi automatic machines and are supplied with central water feed as standard. The system is the culmination of an extensive development programme to give the user optimum performance and superior results when compared to other makes of polishing systems and hence, have become the Professionals number one choice for shaping polished profiles onto edges. Due to the thickness and hard wearing formulation of the resin, the life of these tools is extremely long and cost effective.

This system consists of seven stages; continuous sintered metal bond for rapid stock removal, two grades of electroplated to shape and profile in preparation for polishing and four 4mm thick colour coded resin wheels which produce a fast superior factory finish.



WET GRANITE MARBLE



PRO-GEM TOOLING ADAPTORS

OMA TO 22.2mm BORE

Oma machine adaptor for Pro-Gem profile routing and polishing system.

CONTINENTAL (1/2" BSP) TO 22.2mm BORE

Pro-Gem adaptor continental (1/2" BSP) to fit semi automatic machines.



PROFILE ROUTERS

WET GRANITE

METAL BOND

Available shapes A, B, F, H & V for 20mm and 30mm thickness material. Other sizes on request.

WET MARBLE SLATE

ELECTROPLATED

Available shapes A, B, F, H & V for 20mm and 30mm thickness material. Other sizes on request.



PARALLEL ROUTERS

WET GRANITE

METAL BOND

Size Ø16mm x 40mm coated length, shank Ø12.7mm x 40mm long
Grade 30/40 other grades available, please enquire.

WET MARBLE SLATE

ELECTROPLATED ROUTER

Size Ø8mm x 30mm coated length, shank Ø12.7mm x 45mm long.
Grades 30/36 and 36/44 other grades available on request.



PROFILING



INOX VACUUM BRAZED PROFILE WHEELS

With M14 fitting these wheels have been designed to shape a quarter circle on edges without using a specialised machine! The rotary top and lower bearing guides prevents face and edge damage.



Radius R= 5mm, 15mm, 20mm, 25mm & 30mm
Grade 36/44

Other sizes and grades on request.

INOX VACUUM BRAZED CHAMFER WHEELS

Vacuum Brazed M14 wheels designed to chamfer edges without the need for a specialised machine!



Chamfer sizes 5mm, 20mm & 30mm
Grade 30/40

Other sizes and grades on request.

VACUUM BRAZED PROFILE BURRS

A range of 20 shaping burrs for sculpture and detailed shaping with vacuum brazed diamond coating for strength and long life.



Shank Diameter 6mm
Grades 36/44 & 100/120

KWIK FLUTE CNC ROUTERS

Metal bond CNC routers for producing flutes in granite and marble.



Diameters 12.7mm, 16mm & 20mm
Grades 50, 120, 200 & 400
Fitting M12

Depths of cut (Stage 1) 2mm, (Stage 2) 0.3/0.5mm,
(Stages 3 & 4) 0.1/0.2mm.

Available Kwik Flute Adaptors

CNC Crown Adaptor M12 to ½" BSP

Crown Adaptor with Roller Sleeve M12 to ½" BSP for shaped flutes.

A replacement sleeve is also available.

PROFILING

PRO-CUT CROWNS AND ROUTERS

Pro-Cut Crowns and Routers produce fast clean vanity bowl cutouts and are suitable for use on all popular semi-automatic machines including Thibaut, Ravelli and Bremor. Pro-Cut Routers come complete with the Continental (1/2" B.S.P.) fitting and can be re-tipped. These routers are available with M10 and M12 fittings and used in conjunction with our Continental Roller Guide Adaptor.



M10 CROWN

Dimensions Ø8mm x 10mm, Ø13mm x 13mm, Ø16mm x 20mm & Ø20mm x 20mm

M12 CROWN

Dimension Ø20mm x 20mm

CROWN ADAPTORS

M10 & M12 with roller sleeves (replacement sleeves are available).

ROUTER

Continental with 1/2" BSP fitting



ZENESIS CNC PARALLEL ROUTERS

Zenesis uses the most advanced technology of specially selected diamonds dispersed in triangular patterns within the segments. The benefits include extra segment on tip of tool for recessed hobs, central water feed for increased cutting ability, good cutting speed, long life and competitive prices.



Dimensions 20mm x 40mm & 25mm x 40mm
20mm x 50mm & 25mm x 50mm
Fitting 1/2" BSP

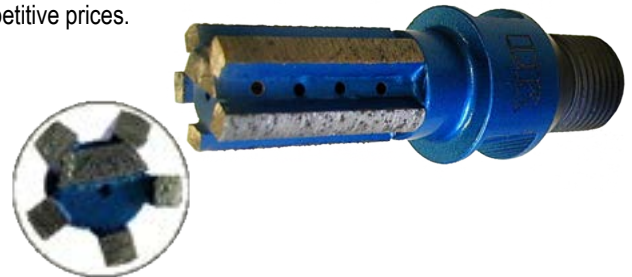

VACUUM BRAZED CNC PARALLEL ROUTERS

Vacuum brazed diamond parallel routers to fit popular CNC and semi-automatic machines and are ideal for cutting out vanity bowls and shaped holes in marble.



Diameter 17mm
Coated Length 55mm
Fitting 1/2" BSP



GRINDING

An extensive range of diamond grinding discs and wheels for hand machines grinding granite, marble, stone, engineered stone and ceramics. All types of fittings are available.



VIKING DISCS

Manufactured with vacuum brazed diamonds for rapid grinding. These discs can be used wet or dry, on both floor and hand held machines.

WET/DRY GRANITE STONE

Diameters 100mm & 125mm
Fittings (Ø100mm) QRS & M14, (Ø125mm) QRS
Grade 30

RAPIER DISC

Vacuum brazed diamond discs for producing architectural detail, chamfering and shaping. M14 spindle makes for easy fitting to most angle grinders.

WET/DRY MARBLE STONE TERRAZZO

Diameter 100mm
Fitting M14
Grade Coarse

DIA-BOARD DISCS

Electroplated diamond grinding discs with QRS colour code backing.

WET/DRY MARBLE STONE

Diameter 100mm
Fitting QRS
Grades Green 50, Black 120 & Red 200

TROJAN DISC

Vacuum brazed diamond with QRS backing for rapid grinding.

WET/DRY GRANITE STONE

Diameter 100mm
Fitting QRS
Grade Coarse

ZODIAC CUP WHEELS

Single or twin rimmed turbo - for smooth finish and extended life.
"T" segment - for rapid stock removal.

WET CONCRETE MASONRY STONE

TWIN RIM
Diameters 100mm - 178mm
Fittings (Ø100mm) 22.2mm bore & M14
(Ø115mm, Ø178mm) 22.2mm bore

'T' SEGMENT
Diameter 100mm
Fitting 22.2mm bore

DIA-GRIND CUP WHEELS

Grinding cup wheels with Ø100mm x 22.2mm bore or Snail-Lock fitting.



Diameter 100mm
 Fittings 22.2mm bore & Snail-Lock
 Grades 30/40 & 60/80



CYCLONE FLAT WHEELS

Grinding wheels with Ø100mm x M14 or Snail-Lock fittings.



Diameter 100mm
 Fittings M14 & Snail-Lock
 Grades Coarse & Fine



TITAN DRY GRINDING DISCS

Developed with vacuum brazed diamond for rapid stock removal. The discs fit directly onto an angle grinder.



Diameters 115mm & 178mm
 Fitting 22.2mm bore
 Grade 40



DIA-DRY DISCS

Electroplated diamond grinding discs.



Diameters 100mm & 180mm
 Bores (Ø100) 16mm bore, (Ø180mm) 22.2mm bore
 Grades 36/44, 44/60 & 60/85



DIANA T30 FLAT DISH WHEELS

T30 dish wheels are Ø100mm with M14 thread for direct mounting onto an angle grinder.



Diameter 100mm
 Fitting M14
 Grades Green 50/60, Red 150/170



GRINDING



METAL BOND MINI GRINDING DRUMS

Mini CNC 25mm diameter drums with central water feed are ideal for grinding tight corners and produce a good honed finish on granite and Engineered Stone edges. Can be used as an option in place of electroplated Mini Chevron Drums.

WET	CNC	GRANITE	ENGINEERED STONE
-----	-----	---------	------------------

Dimension	25mm x 40mm
Fitting	1/2" BSP/M14
Grades	MB1-50, MB2-120, MB3-200 & MB4-400



VACUUM BRAZED DRUMS

With M14 fitting for use on Angle grinders. Can be used to grind inside sink cut-outs. The vacuum brazed diamonds allow rapid grinding with good life.

WET/DRY	GRANITE	MARBLE	STONE
---------	---------	--------	-------

Diameters	20mm - 82mm
Length	40mm - 50mm
Fitting	M14
Grades	40 & 50



CUSHIONED DRUMS

These electroplated diamond cushioned drums with M14 fitting are a versatile solution for grinding apertures.

WET/DRY	GRANITE	MARBLE	STONE
---------	---------	--------	-------

Diameters	50mm & 75mm
Length	50mm
Fitting	M14
Grades	36/44 & 60/85



DRUM ADAPTOR

Drum Adaptor for (1/2" BSP), Continental to M14 fitting for 50mm/75mm diameters Cushioned and Vacuum Brazed Drums.



GS DRUM

Metal bond segmented drum, designed for rapid stock removal.

WET/DRY	GRANITE	STONE
---------	---------	-------

Dimension	75mm x 35mm
Fitting	M14

METAL BOND WHEELS

Metal Bond diamond wheels for grinding and calibrating slabs to size.

WET

GRANITE

STANDARD

Diameters 350mm - 400mm
Widths 20mm, 25mm & 40mm
Fitting 60mm/50mm bore

PREMIUM

Diameters 300mm - 450mm
Widths 20mm & 25mm
Fitting 60mm/50mm bore



Bores can be machined to customer's requirements.

SD MILLING WHEELS

For recessing drainers, premium fast grinding wheels for use on popular Semi Automatic machines.

WET

GRANITE

Dimension 86mm x 30mm
Fitting 50mm bore



Available 1/2" BSP SD Continental Adaptor

UNDER CHAMFER TOOL

The Under Chamfer Tool is the ideal way to produce a chamfer on the underside in sinks, counter tops and slabs. Recommended speed 3,000 - 6,000 rpm. For use on CNC and semi-automatic machines.

WET

CNC

GRANITE

ENGINEERED
STONE

Dimension Ø30mm x 45mm
Fitting 1/2" BSP



LINE BREAKERS

Designed and manufactured to remove tram lines and machine marks.

WET

CNC

GRANITE

ENGINEERED
STONE

Diameters 15mm - 80mm
Length 40mm
Fittings 22mm and 35mm bores or 1/2" BSP



POLISHING

ELECTROFLEX DIAMOND PRODUCTS

A range of well proven diamond polishing systems which are colour coded for easy grade identification and this colour coding is applicable to all Electroflex polishing systems. Electroflex material combines the long life and aggressive cutting action of diamond with the flexibility of the backing material, enabling tools in various shapes to quickly grind and polish stone, marble and other hard materials.

Normally for marble, granite, engineered stone and terrazzo materials seven grades are recommended.

METAL Green , Black, Red, Gold, Yellow, White & Blue
RESIN White, Blue and Orange

ELECTROFLEX DISCS

For wet polishing on hand and fixed machines. All sizes, grades, backings and fixings available including QRS, self-adhesive, M14 and snail-lock.

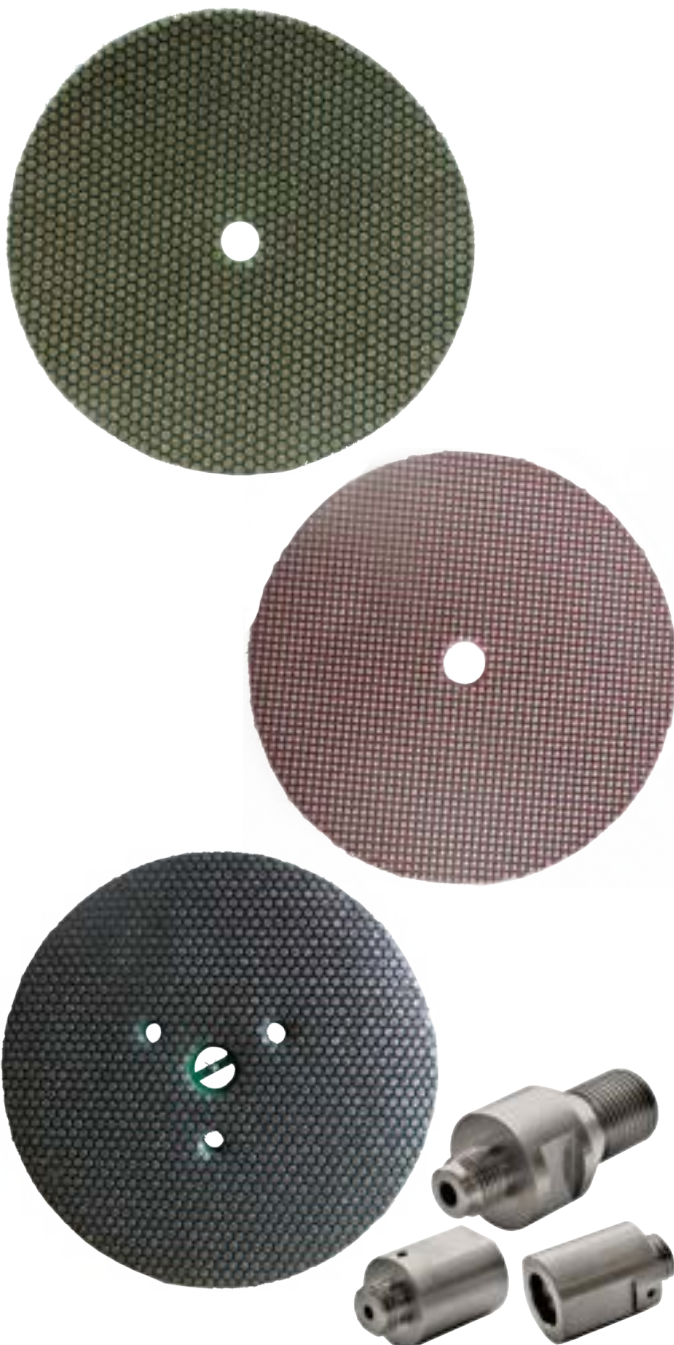

QRS BACKED DISCS

Quick Release Backed Discs

WET	GRANITE	MARBLE	STONE	ENGINEERED STONE	TERRAZZO
-----	---------	--------	-------	------------------	----------

Diameter 100mm
Grades M60 - R12000

QRS BACKUP PADS

Diameter 100mm
SINGLE CENTRAL WATER FEED HOLE - FLAT & CUSHIONED
Fittings M14, M16 & Snail-Lock
RUBBER - SEMI RIGID
Fitting M14
ALUMINIUM
Fitting M14

SELF-ADHESIVE DISCS

S/A Backed Discs for use with electric and air tools.

WET	GRANITE	MARBLE	STONE	ENGINEERED STONE	TERRAZZO
-----	---------	--------	-------	------------------	----------

Diameter 100mm
Grades M60 - R12000

M14 DISCS

Diamond flexible discs Ø100mm with M14 backing

WET	GRANITE	MARBLE	STONE	ENGINEERED STONE	TERRAZZO
-----	---------	--------	-------	------------------	----------

Diameter 100mm
Grades M60 - R12000

M14 DISC ADAPTORS

Adaptor enables the use of a M14 plastic backed disc, stopping the machine thread from pushing through to the polishing face of the disc.

Fittings M16 - M14, M14 - M14 & Continental to M14

POLISHING

ELECTROFLEX FLEXIBLE DIAMOND HAND PADS

For grinding and polishing the edges and surfaces of a wide range of materials. All hand pads have colour coded foam backing for easy grade identification.

FLAT



Dimensions 75mm x 75mm, 90mm x 55mm
Grades M60 - R12000



CUSHIONED



Dimensions 90mm x 55mm, 100mm x 55mm
Grades M60 - R12000

PROFILED



Material Thicknesses 20mm, 30mm & 40mm
Grades M60 - R12000

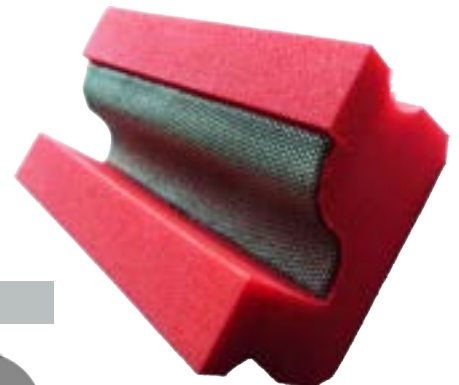

OTHER PROFILES ALSO AVAILABLE



DIA-MET DIAMOND HAND PADS



For rapid hand grinding.

Grades 60, 120 & 200



POLISHING

EXPANDING RUBBER DRUM BELTS

Good quality, long lasting, Electroflex flexible diamond colour coded belts for use on expanding rubber drums for grinding, shaping and polishing internal cut-outs and flat edges.

WET	GRANITE	MARBLE	STONE	ENGINEERED STONE	TERRAZZO
-----	---------	--------	-------	------------------	----------

Dimensions Ø75mm x 38mm wide, Ø75mm x 50mm wide
 Ø100mm x 38mm wide, Ø150mm x 38mm wide
 Grades M60 - R12000

EXPANDING RUBBER DRUMS

Dimensions Ø75mm x Ø25mm bore,
 Ø100mm x Ø25mm bore &
 Ø150mm x Ø50 mm bore

A bore reducing bush is available.

RUBBER DRUM ADAPTOR

Continental to 75mm/100mm Expanding Rubber Drum for use on semi automatic machines.



EXPANDING RUBBER MANDREL BELTS

Flexible diamond continuous spiral bands for use with rubber mandrels that expand when in use securely holding the band, have been designed for light grinding, shaping and polishing.

WET	GRANITE	MARBLE	STONE	ENGINEERED STONE	TERRAZZO
-----	---------	--------	-------	------------------	----------

Dimensions Ø10mm x 20mm wide, Ø15mm x 30mm wide
 Ø22mm x 20mm wide, Ø25mm x 25mm wide
 Ø30mm x 30mm wide, Ø45mm x 30mm wide

Grades M60 - R12000

EXPANDING RUBBER MANDRELS

Dimensions Ø10mm x 20mm, Ø15mm x 30mm
 Ø22mm x 20mm, Ø25mm x 25mm
 Ø30mm x 30mm, Ø45mm x 30mm

Shank Ø6mm

VANITY DRUMS

M14 fitting Electroflex drums with central water feed for hand or machine grinding and polishing internal cutouts.

WET	GRANITE	MARBLE	STONE	ENGINEERED STONE	TERRAZZO
-----	---------	--------	-------	------------------	----------

Dimensions Ø50mm x 42mm wide, Ø75mm x 50mm wide
 Grades M60 - R12000

DRUM ADAPTOR

Drum Adaptor for (1/2" BSP), Continental to M14 fitting for 50mm/75mm diameters Electroflex Vanity Drums.



ELECTROFLEX HAND FILES



General purpose files, used wet in grades Black M120, Red M200, Yellow M400 and White M800. Supplied individually or in a wallet set of 4 different profiles.

Metal Grades M120 - M800 grit



PROFILE NO. 1



PROFILE NO. 2



PROFILE NO. 3



PROFILE NO. 4

DIAMOND SHARP BLOCK

Diamond Electroflex strips set on a plastic block specifically for sharpening, chisels and knives.

WET/DRY

Available as
BLOCK WITH DOUBLE STRIPS

Grades M200 & M400

REPLACEMENT STRIPS

Dimensions 135mm x 50mm & 135mm x 25mm

Grades M120, M200 & M400



ORBITAL SANDER SHEETS



EOS502 Electroflex diamond flexible QRS backed pads for grinding and polishing flat surfaces and up into tight corners.

Dimension 210mm long x 115mm wide

Grades M60 - R12000

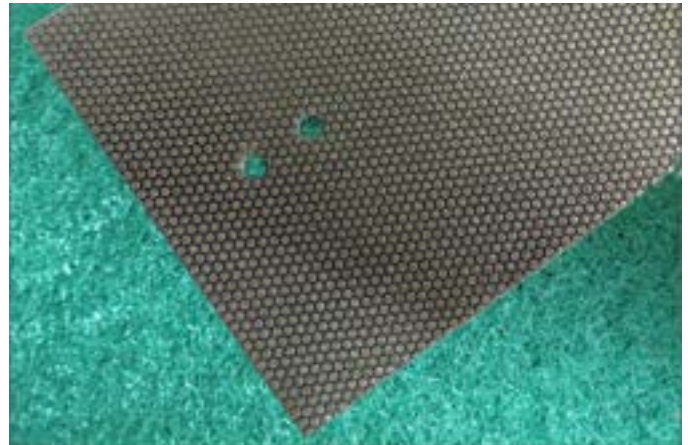

FLEXIBLE SHEETS

For hand polishing, Electroflex material can be supplied in sheets of various sizes and backings including unbacked (canvas), QRS (quick release), self-adhesive and Plastazote.



Most popular sheet size is 100mm x 55mm with unbacked or plastazote backings. Other sizes and backings available on request.

Grades:

Metal Grades 60 - 120 – Sheet Dimensions 850mm x 290mm

Metal Grades 200 - 1800 – Sheet Dimensions 3000mm x 290mm

Resin Grades 800 - 12000 – Sheet Dimensions 650mm x 290mm

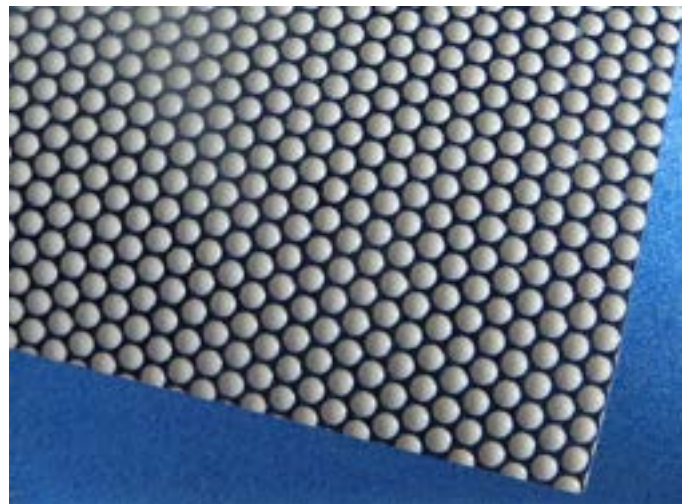

POLISHING



DK 3 STEP POLISHING SYSTEM

Diamond 3 Step system with QRS backing for polishing with only three stages saving both time and money while quickly achieving a very professional finish, particularly when used wet.

WET/DRY	GRANITE	ENGINEERED STONE
---------	---------	------------------

Diameters	100mm & 125mm
Stages	1, 2 & 3

Sold in complete sets of 3 or individually.



CERAMICA DISCS

Flexible resin discs for dry polishing, quickly achieving high gloss finish. QRS backed 100mm diameter discs with a maximum speed of 2500 rpm.

WET/DRY	GRANITE	MARBLE	ENGINEERED STONE
---------	---------	--------	------------------

Diameter	100mm
Grades	50, 100, 200, 400, 800, 1500, 3000, Black Buff & White Buff

Sold in complete sets, grade 50 to Black Buff or individually.



SUPREME DISCS

These all-in-one Ø100mm, QRS backed super flexible diamond discs have been manufactured incorporating advanced stone polishing technology specially formulated to reduce stages down to 5, to increase speed of operation, and to give a better finish.

WET	GRANITE	MARBLE	ENGINEERED STONE	TERRAZZO
-----	---------	--------	------------------	----------

Diameter	100mm
Stages	1, 2, 3, 4 & 5

Sold in complete sets of 5 or individually.

PANTHER DISCS

Flexible resin diamond polishing discs are ideal for achieving an excellent high gloss finish. These 100mm diameter QRS backed discs are very fast working and are 3mm thick giving long life.

WET

GRANITE

ENGINEERED
STONE

Diameter 100mm
Grades 50, 100, 200, 400, 800, 1500, 3000,
Brown Buff & Black Buff

Sold in complete sets or individually.



KWIK-FLEX DISCS

Flexible disc polishing system having been developed from the Dia-Dot formula with many improvements using advanced diamond bond technology resulting in up to 30% extra life and less time per grade to achieve a superior high gloss finish.

WET

GRANITE

Diameters 80mm, 100mm & 125mm
Grades 60, 120, 200, 400, 1000, 2000, 10000



PUMA DISCS

A good performing Ø100mm flexible diamond resin disc available at a very competitive price. These discs very quickly grind and polish, achieving a high gloss polished finish.

WET

GRANITE

Diameter 100mm
Grades 50, 100, 200, 400, 800, 1500, 3000, Green Buff

Sold in complete sets, grade 50 to Green Buff or individually.

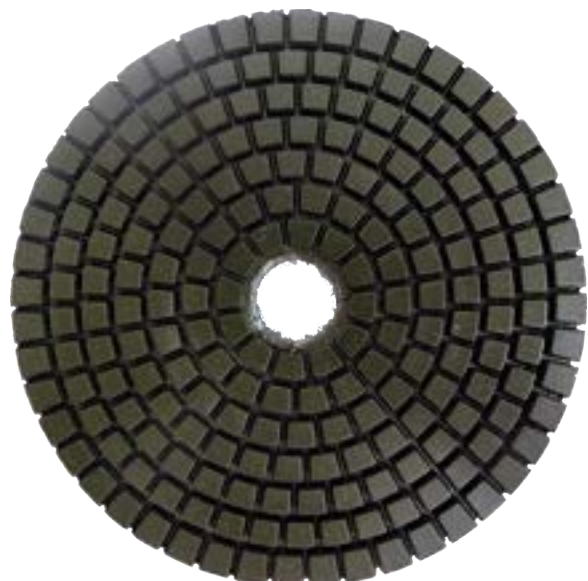

POLISHING

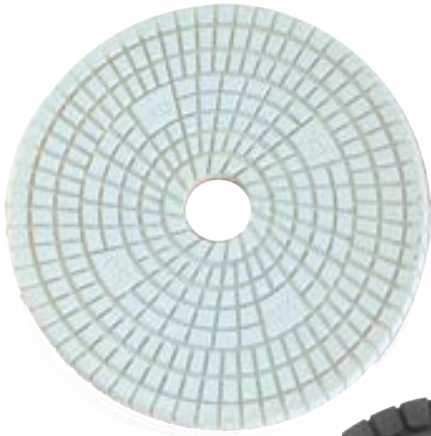

DIA-GEM DISCS

Flexible resin diamond discs for polishing with all grades in white resin to ensure no staining on light coloured marble. Coloured coded by QRS backing.

WET MARBLE

Diameter 100mm
Grades 60, 140, 300, 800, 1200, 1800, 12000



DIA-DOT SOLID DISCS

Premium solid discs for polishing flat surfaces. Colour coded by backing in Ø100mm with M14 or snail-lock fittings.

WET GRANITE

Diameter 100mm
Fittings M14 & Snail-Lock
Grades 60, 120, 200, 400, 1000 & 2000



DIA-SOL DISCS

A premium solid disc for polishing flat edges. Colour Coded by backing in Ø100mm with M14 or snail-lock fittings.

WET GRANITE

Diameter 100mm
Fittings M14 & Snail-Lock
Grades 60, 120, 200, 400, 1000, 2000 & 10000



DISC ADAPTORS & BACKUP PADS

Disc adaptor stops the machine thread from pushing through to the polishing face of the disc when using M14 plastic backed discs.

M14 DISC ADAPTORS

Available Fittings M14 to Snail-Lock, M14 to M14 & Continental to M14

QRS BACKUP PADS

SINGLE CENTRAL WATER FEED HOLE - FLAT & CUSHIONED

Diameters 80mm, 100mm & 125mm
Fitting M14

ALUMINIUM

Diameter 100mm
Fitting M14

POLISHING

EMPEROR EDGING WHEELS

A range of Ø125mm edge polishing wheels that achieve an excellent natural polished finish. Designed for most popular edging machines. Sold in complete sets of 8 or individually.

WET	GRANITE	MARBLE	ENGINEERED STONE
-----	---------	--------	------------------

Diameter	125mm
Fittings	Snail-Lock & QRS
Grades	Green Conditioner, 50, 100, 200, 400, 800, 1500, 3000 & Buff.

EMPEROR ARRISING WHEELS

A resin wheel manufactured for arissing stone slabs.

Dimension	130mm x 35mm x 55mm
Fitting	Snail-Lock
Grade	Green Conditioner

PRESIDENT EDGING WHEELS

Premium edging wheels for polishing in Ø100mm, Ø130mm and Ø150mm with snail-lock backing. Rubber gaskets included.

WET	GRANITE
-----	---------

Diameters	100mm, 130mm & 150mm
Fitting	Snail-Lock
Grades	60, 120, 200, 400, 1000, 2000 & 10000

DIA-DOT EDGING WHEELS

Edging wheels Ø130mm with snail-lock backing. Rubber gaskets included.

WET	GRANITE
-----	---------

Diameter	130mm
Fitting	Snail-Lock
Grades	Green Conditioner, 60, 120, 200, 400, 1000 & 2000

BACKUP PADS

QRS TO SNAIL-LOCK

For use on Emperor Edge Wheels

Diameters 125mm & 150mm

M14 TO SNAIL-LOCK

Fit snail-lock polishing discs.

Diameters 100mm & 130mm

EDGING WHEEL GASKET

Replacement gaskets for Ø130mm edge polishing wheels. A Hexagonal Spanner is also available.

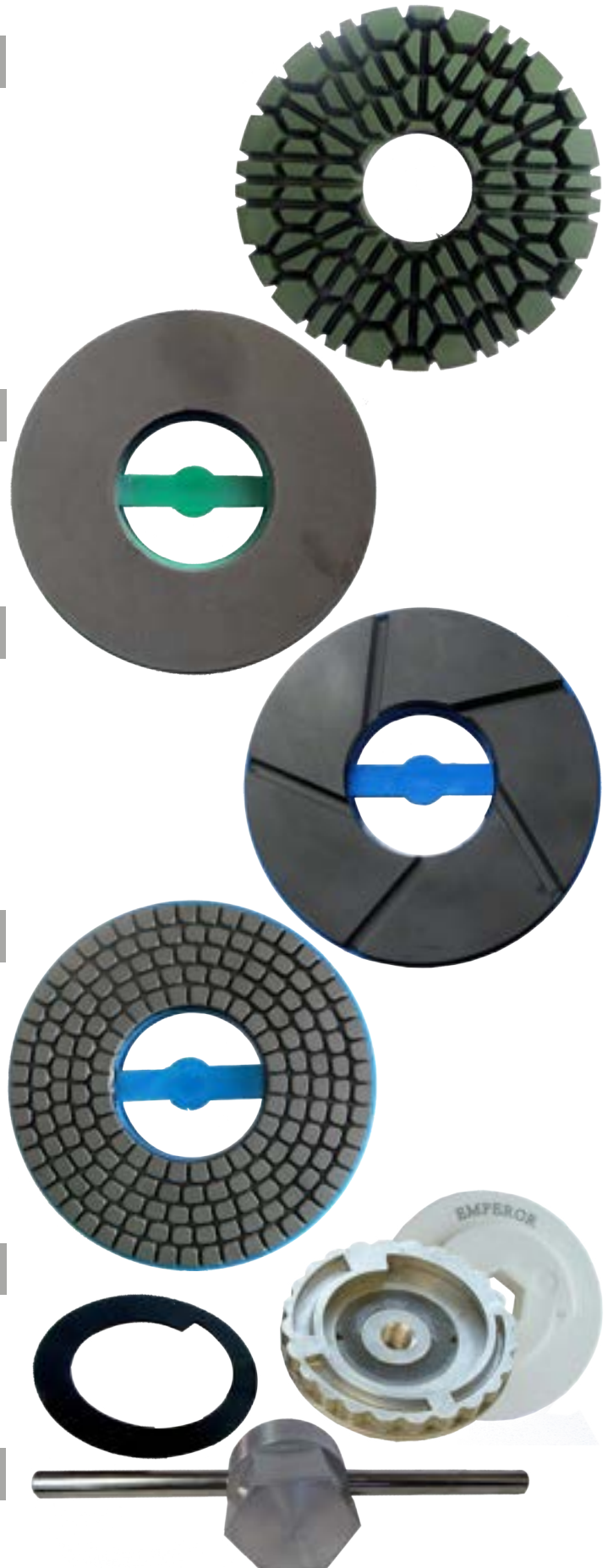

POLISHING



RHINO RADIAL ARM POLISHING DISCS

The surface grinding and polishing QRS backed discs achieve the required prepared finish right through to a high gloss using standard and glossier blocks. The first two metal bond discs are optional depending on the condition of the surface and when used, the first two stages can then be missed out.



Diameter 250mm
Grades Metal Bond: 40/50 & 150/170 (Optional), Green 60, Black 120, Red 200, Yellow 600.



DIA-RAP RADIAL ARM POLISHING DISCS

Premium Ø250mm surface grinding/polishing system with colour coded QRS backing. Can be used on a Jenny Lind and other popular radial arm polishing machines.



Diameter 250mm
Grades Metal Bond: Coarse & Fine, Green 60, Black 120, Red 200, Yellow 400, White 1000, Blue 2000, Orange 10000.



TWISTER RADIAL ARM POLISHING DISCS

QRS colour coded backed discs achieving fast stock removal and a high gloss finish.



Diameter 250mm
Grades Metal Bond: Coarse & Fine, Black 200, Red 400, Yellow 800, White 1500, Blue 3000, Orange Buff.



RADIAL ARM QRS CONVERTER & BUFFER

Backing plates and Felt Buffer Pad to fit on Radial Arm Polishing Machines.

POLISHING

CHEVRON RESIN DRUMS FOR CNC

Grades are easily identified by colour marking.

Various bore sizes are offered to fit the wide range of CNC machines in the market. For example: 35mm and 22mm diameter for the Inter-mac and 20mm diameter for the Prussiani and Brembana.

WET	CNC	GRANITE	HARD STONE
-----	-----	---------	------------

Diameters	50mm & 75mm
Widths	38mm & 50mm
Bores	Various
Grades	60, 120, 200, 400, 1000, 2000 & 10000.



CHEVRON RESIN DRUMS

For hand and machine polishing, can be preceded by grinding drums.

WET	GRANITE	STONE
-----	---------	-------

Diameters	50mm & 75mm
Width	50mm
Fitting	M14
Grades	60, 120, 200, 400, 1000 & 2000.
Available Adaptor	For (1/2" BSP), Continental to M14 fitting.



CHEVRON BELTS

Hard wearing resin bond impregnated with high quality diamonds to give fast aggressive cutting action. These belts achieve a high gloss finish and are specifically designed to fit expanding rubber drums. Simple identification clear grit colour code marking.

WET	GRANITE	STONE
-----	---------	-------

Diameter	75mm
Widths	38mm & 50mm
Grades	60, 120, 200, 400, 1000, 2000 & 10000.

EXPANDING RUBBER DRUM & ADAPTOR

Drum available for Ø75mm x 38mm x 25mm
Adaptor Continental to 75mm/100mm



CHEVRON DRESSING BAR

Diamond dressing bar specifically designed for dressing Chevron type diamond resin drums and belts.

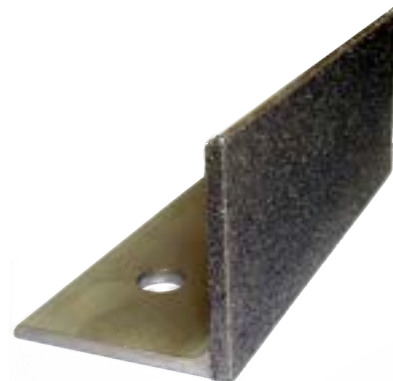

POLISHING



MINI CHEVRON DRUMS

The small Mini Chevron drums allows for grinding and polishing tight corners in kitchen tops to suit the latest style of sinks. An excellent natural polished finish is quickly achieved with very good tool life. The system comprises of 2 electroplated diamond cushioned drums and 5 resin diamond polishers.

WET	GRANITE	STONE
-----	---------	-------

Sizes	Electroplated: Ø25mm x 50mm Resin: Ø25mm x 38mm
Fitting	M14
Grades	Electroplated: 60/85 & 150/170 Resin: 200, 400, 1000, 2000 & 10000.
Drum Adaptor	For (½" BSP), Continental to M14 fitting.



STARLITE DRUMS

A range of diamond impregnated resin drums designed for polishing the inside of bowls.

WET	GRANITE	STONE
-----	---------	-------

Diameters	50mm & 75mm
Width	42mm
Grades	50, 100, 200, 400, 800, 1500, 3000 & Buff
Adaptor	Quick Release



CERAMICA RESIN DRUMS

Designed to give a high gloss finish on granite, engineered stone and marble.

WET/DRY	GRANITE	MARBLE	ENGINEERED STONE
---------	---------	--------	------------------

Diameters	50mm & 75mm
Width	42mm
Fitting	M14 thread attaching direct to your polisher.
Grades	50, 100, 200, 400, 800, 1500, 3000 & Buff.

ULTRA MINI CNC ROUTERS

These polishing routers grind and polish straight edges with very tight corners of 10mm radius.

Sold individually or as a complete set with 4 adaptors.



Size $\varnothing 20\text{mm} \times 40\text{mm}$

Adaptor $\frac{1}{2}$ " BSP



ULTRA MINI 45° BEVELLING ROUTERS

The 45° Bevel $\varnothing 20\text{mm}$ polishing routers allow the grinding and polishing of bowl cutouts with very tight corners of 10mm radius creating a 45° bevelled top edge.



Size $\varnothing 20\text{mm} \times 40\text{mm}$

Adaptor $\frac{1}{2}$ " BSP



ULTRA MINI 5mm RADIUSING ROUTERS

These 5mm Radiused $\varnothing 20\text{mm}$ routers allow the grinding and polishing of bowl cutouts with very tight corners of 10mm radius creating a 5mm radiused top edge.



Size $\varnothing 20\text{mm} \times 40\text{mm}$

Adaptor $\frac{1}{2}$ " BSP



POLISHING

FLUTEMASTER SYSTEM

Improved flute grinding and polishing system, easy to setup, lighter and quicker with smoother operation than previous systems. It incorporates a simple system for height adjustment and will work inside recessed draining boards as well as on flat surfaces. Flutes are ground and polished in minutes rather than hours. Using a standard 110v variable speed Flex machine with the unique diamond electroplated and resin wheels manufactured in-house, the system will do both grinding and polishing operations without moving the workpiece. The system is available in 10mm, 12.7mm, 16mm and 20mm widths, colour coded for easy grade identification. Optional guide wheel available for fluting into contoured shapes.

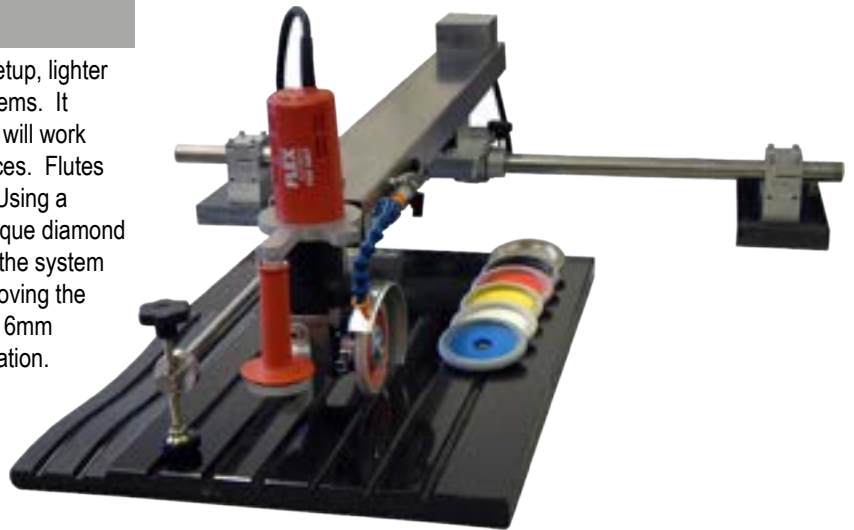

COMPLETE FLUTING SYSTEM comprises of 1 Flutemaster machine, 1 Flex machine, 1 Electroplated Wheel, 1 Black - Blue flute wheels, 2 felt wheels, 1 marble compound and 1 granite compound.

Available as a complete system or items can be purchased individually



FLUTE POLISHING SYSTEM

Polishing flutes by hand is a very tedious and time consuming operation. The flute polishing system will rapidly achieve very highly polished flutes, in minutes rather than hours. The system is based around special coloured coded diamond resin wheels that operate at optimum performance with long life. These wheels are used with a fast and reliable air powered machine, felt wheels and final polishing powders. Widths available 10mm, 12.7mm, 16mm and 20mm. Profile wheels (electroplated) with correct width and radius to grind the flute can be supplied to order.



COMPLETE POLISHING SYSTEM comprises of 1 Air Machine, 1 Black - Blue flute wheels, 2 felt wheels, 1 case, 1 marble compound, 1 granite compound and 2 spanners.

Available as a complete system or items can be purchased individually.



POLISHING

FLUTE POLISHING WHEELS

These Flute Wheels have been designed and manufactured by DK Holdings for the rapid achievement of very highly polished flutes in recessed draining boards. The resin fluting wheels are colour coded and will give optimum performance with long life. The electroplated profile wheel with correct width and radius will grind the exact flute required.

WET	GRANITE	MARBLE	ENGINEERED STONE
-----	---------	--------	------------------

Diameters 10mm, 12.7mm, 16mm & 20mm.
 Grades 60, 120, 200, 400, 1000, 2000 & Felt Buff.
 Available in sets or individually.

DRESSING BLOCK also available in 10mm, 12.7mm, 16mm & 20mm

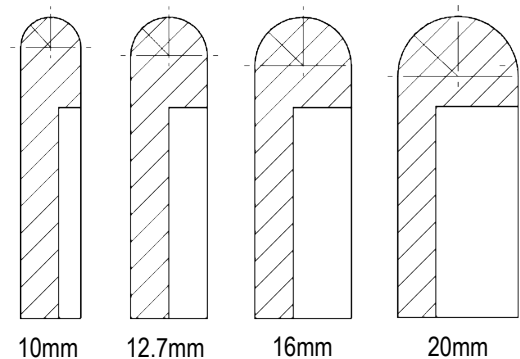
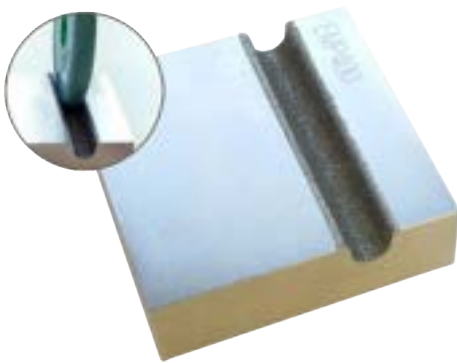

FLUTE WHEELS FOR SEELBACH MACHINE

After the flute grooves have been ground follow with these flute polishing wheels to produce an excellent polished finish.

WET	CNC	GRANITE	MARBLE	ENGINEERED STONE
-----	-----	---------	--------	------------------

Diameter 200mm
 Width 12.7mm
 Bore 22.2mm
 Grades Red 200, White 1000, Blue 2000 & Felt



FLUTE GRINDING & POLISHING WHEELS

A two stage flute grinding system for most types of CNC and semi automatic machines.

WET	CNC	GRANITE	MARBLE	ENGINEERED STONE
-----	-----	---------	--------	------------------

Diameters Intermac 140mm & Full Radius 200mm
 Widths 12.7mm & 10mm
 Bores 30mm & 50mm
 Grades Metal Bond & Resin 400
 Other sizes and grades available on request.



ACCESSORIES

REPAIRLUX REPAIR KITS

The system makes use of new technologies and offers many advantages, including fillers integrated with adhesion promoters doing away with primers, coloured fillers are already premixed with transparent liquid fillers so these can be directly cured and special mica fillers blended with coloured fillers produce a gloss effect ideal for reflective surfaces. Although natural stone is exceptionally hard it can still be scratched or the edges can be damaged and now technicians have developed this kit which can be used on both granite and marble so there is no longer a need for two systems. Finally, apart from the advantageous price, the flexibility of the kit is also ideal for the market as it is available as a Complete Kit form with replacement components individually available.

GRANITE

MARBLE

ENGINEERED
STONE

COMPLETE KIT COMPRISES:

1 x Transparent Liquid, 1 x Transparent Base, Fillers x 1 each Black, White, Marble, Green, Yellow, Blue, Red & Beige, 6 x Granulates (various), Mica x 1 each Silver & Gold, 15 x Cannula, 1 x Metal Applicator, 1 x Cuttlebone, 1 x Plastic Film (10 pcs), 1 x Metal Planer, 1 x Black Touch-up Pen, 1 x Polishing Block, 1 x Cotton Cloth, 1 x Polishing Paste, 1 x Mixing Cup, 1 x Cleaning Solution, 3 x Micro Sanding Paper, 1 x Brass Brush, 1 x Power Light, 1 x Diamond Drill Bit Set (20 pcs), 1 x Training DVD.

REPAIRLUX TRAINING SEMINAR

Full day training course 9 am — 3.30 pm

(Maximum 8 people per session)

Please contact for further details.



DK STONE CARE PRODUCTS

DK Holdings has worked very closely with a leading European manufacturer of Glues, Waxes and Natural Stone Treatments to produce our own range of the highest quality performing stone care product at competitive prices. All of these products are of proven quality to give the best performance and long life in each product group.



DK SUPER STONE GLUE

Polyester resin adhesive for gluing Granite, Marble, Terrazzo, Engineered Stone and Natural Stone. Can also be used as putty for filling cavities or cracks. Tub of Polyester Resin Hardener included.

Available in colours: Transparent, Straw, White and Black.

DK POLYESTER RESIN HARDENER

Additional tubes of Polyester Resin Hardener.



SYRINGE

10ml Syringe for liquid glues.



DK SUPER CLEANER (PH Neutral)

Universal concentrated PH Neutral detergent for cleaning and maintenance of all hard and resilient surfaces such as Granite, Marble, Slate, Natural Stone, treated Terracotta, Porcelain, Stoneware and Ceramics. Can be diluted as necessary.

DK STOP STAINS

S - Solvent Based (For inside and outside)
Protective oil-repellent for Granite, Marble, Natural Stones, Terrazzo and Terracotta.

A - Water Based (For inside and outside)
Water-repellent with anti-stain properties. Forms a surface barrier against watery and greasy dirt. Specially suited to Natural Stone, Marble, Granite, Slate, Terrazzo, Tiles and Terracotta.



DK SUPER COLOUR ENHANCER

For polished Granite and Stone. Wet effect, fills micro cracks and small fissures. Recommended for Zimbabwe Black.



DK COLOUR ENHANCER

Water Repellent for outside use on unpolished Granite and Stone. Matt finish.

Oil Repellent for inside use on unpolished Granite and Stone. Semi-Gloss finish.

DK COLOUR CORRECTORS

Available in 1Lt container for Zimba Black and Imprim RTF.



ACCESSORIES

DK STONE CARE PRODUCTS

GRANITE

MARBLE

STONE

DK LIQUID WAX

Special polishing liquid wax for Marble, Granite, polished or smoothed Marble Agglomerates.

DK WAX PASTE

Special black paste wax based on Brazilian Carnauba and natural beeswax for Marble, Granite and Natural Stone.



DK BUFFING PAD

Natural Lambswool, Ø125mm.



FELT MOP DONUT

Ideal for a perfect finish, these felt mops are for use after polishing pads when applying buff liquid polishing compound and powders. Available in diameters 125mm and 180mm, 50mm thick. M14 fitting.



FELT PADS

Final polishing stage felt 100mm buffing pads, with M14, Snail-Lock and QRS fittings, can be used with polishing liquid compound on granite when high gloss finish is required.



LIQUID POLISHING COMPOUND

Designed to be used with buffing pads to help produce a high gloss finish on both light and dark granites.

GRANITE



POLISHING POWDER COMPOUND

Final polishing powders for marble and granite.

GRANITE

MARBLE



ACCESSORIES



CERAMIC TILE DRILLING KIT

A very handy, kit for drilling holes in tiles using a standard, variable speed drill. Supplied in a compact case containing everything that you need to drill screw holes in tiles. Drill Bits and replacement parts are also available individually.

KIT INCLUDES:

6, 8 and 10mm Tile Drill Kit, Mini Guide and Case.

WET

MARBLE

CERAMICS

TRANSLUCENT TEMPLATING MATERIAL

Versatile, lightweight, yet durable twin wall polypropylene sheet material successfully used by Kitchen and Worktop installers, offering a cost effective solution to traditional methods. Tolerance on straightness 4mm per metre.

Available in

100 sheet packs .7m x 3.1m x 2mm

100 sheet packs & 600 sheet pallet .7m x 3.1m x 3mm

100 sheet packs & 375 sheet pallet 1.2m x 2.4m x 3mm

DF TAPE

Clear PVC tape for template jointing 50mm wide x 33m.

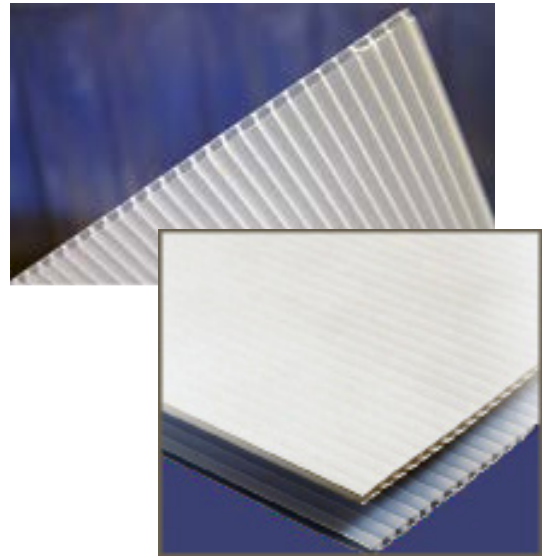

GRP REINFORCING BAR

For strengthening large sized stone worktops. Perfect replacement for reinforcing steel bars - do not rust, are light, easy to handle, cost effective and extremely strong with grooves for glue.

75 METRE PACKS

Bar Dimensions 3m x 15mm x 2.5mm & 3m x 10mm x 2.5mm

100 METRE ROLL

Bar Dimension 10mm x 3mm

A stand is also available for the Roll.

Liquid glue available in 10ml syringe.

HAND MACHINES

FLEX 110v WET & DRY POLISHERS

WET POLISHER with centre water feed, 3,600 rpm.
Accessories: M14-M14 Adaptor and Open End Spanner,
Splashguard, 3m Hose including male couplings

DRY POLISHER variable speed 0-3,700 rpm.
Accessories: Flange with lock-nut and spanner

Twin Outlet Transformer
240v - 3 x 110v outlets

Back-up Pad Flat type with M14 fitting.



FEIN MULTIMASTER MM 700

The Fein Multimaster MM 700 is used for dry polishing or grout removal.

DRY POLISHER variable speed 10,000-19,500
Accessories Back-up Pad StarLockMax for sanding
with Electroflex QRS Pads



QUICK Q-6R PNEUMATIC WET POLISHER

Variable speed polisher with central water feed, rear exhaust and M14 fitting.



HAND MACHINES

AS100 ANGLE SAW

The AS100 is a very powerful robust machine developing 1.5HP. Fast cutting, with very effective dust extraction for cutting up to 25mm deep. Can also be used wet. Supplied with combined saw guard and dust extraction cowl and safety lever throttle.



AS125 ANGLE SAW

The AS125 has the same power and specifications as the AS100. It has been designed to accept larger diameter saws for applications requiring a greater depth of cut and will cut up to 35mm deep. Can also be used wet. Supplied as standard with safety lever throttle.

Optional soleplate and handle with adjustable depth gauge attachment available providing precise cutting depth of up to 35mm.



STONE FLOORING

DEMONSTRATION FLOOR AREA

At our Staplehurst factory we have a purpose built floor area laid with various types of stone so that we can offer demonstrations for the machines and diamond systems we supply. A full technical support service is available from our technical department.

HIRE SERVICE

A hire service is available for our UK customers, which allows a very cost effective availability of machines and diamond systems if the need is intermittent.



NUMATIC NR-1500H



DK T8



TORNADO T10

STONE FLOORING

DIAMOND POLISHING PADS

The diamond impregnated DK Typhoon and Typhoon Max Floor Polishing Pads are a quick and easy way to maintain and polish floors with their easy to follow stages. The pads are suitable for use on various surfaces such as Marble, Terrazzo, Granite, Ceramic tiles, Resin, Concrete and Acrylic Flooring.



DK Typhoon Pads

(available in 125, 400 & 430mm
(5, 16 & 17in)



Stage 1 (400 grit)
Used to remove light to medium scratches and marks.



Stage 2 (800 grit)
Used to remove light scratches.



Stage 3 (1800 grit)
The start of the polishing process, can be used daily.



Stage 4 (3000 grit)
Used daily to maintain and improve the polish, resulting in the highest shine.

DK Typhoon Max Pads

Made from natural hair fibre
Use prior to Stage 1 of the DK Typhoon Pads to remove deep scratches and marks in heavily worn floors.
(available in 400 & 430mm (16 & 17in)



(50 grit / Green)



(100 grit / Black)



(200 grit / Red)

STRIP – REPLATE – REDRESS SERVICE

SAVE up to 40% by giving your old tools a new lease of life using DK's STRIP & REPLATE or RE-TIP SERVICE! Please contact DK for a quotation.

STRIP & REPLATE SERVICE

FOR ELECTROPLATED TOOLS:

- Continuous Rim Blades
- Profile Wheels
- Various CNC Tooling
- Flute Wheels
- Parallel Routers

RE-TIP SERVICE

FOR METAL BOND TOOLS:

- Multicut Core Drills
- Routers (Metal Bond)
- Milling Wheels
- Drums



REGRINDING & REPROFILING SERVICE

METAL BOND TOOLS

DK Holdings offer our customers an in house regrind and reprofile service. We can deliver a prompt and accurate return with minimal stock removal to ensure the maximum life for our customer's tools.

This service includes profile tools and routers.

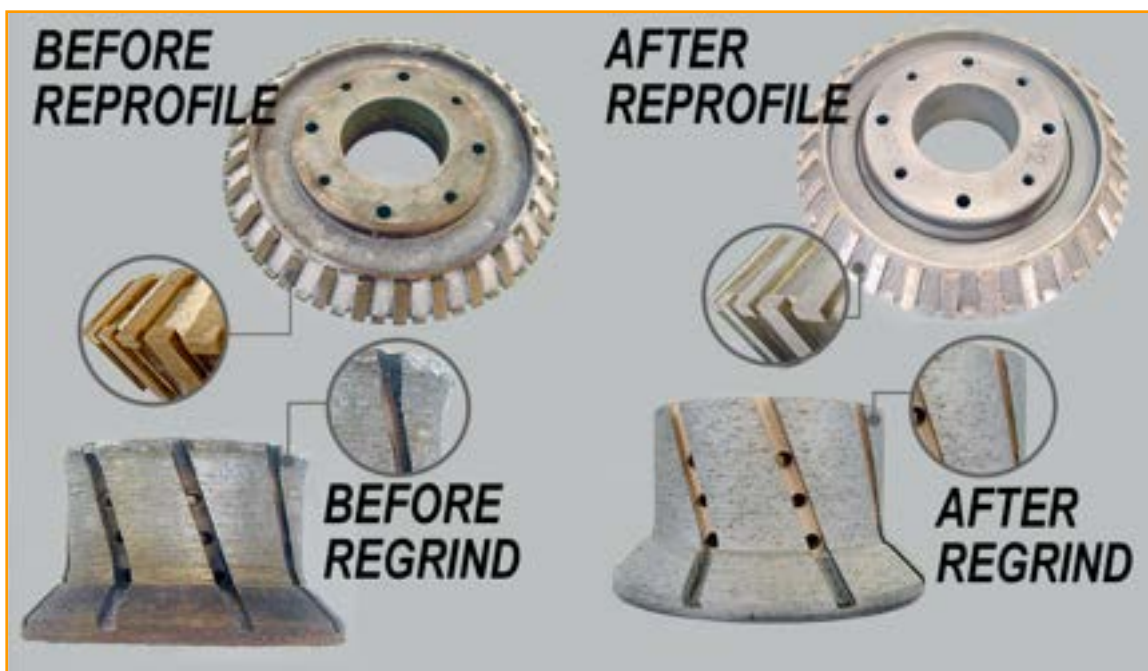

BUSINESS TERMS

BUSINESS HOURS

Monday — Friday : 8.00 am - 5.00 pm

ORDERING IS EASY

Contact us on:



TELEPHONE - +44 (0)1580 891662



FAX - +44 (0)1580 892724



E-MAIL - sales@dk-holdings.co.uk



Or alternatively post your order to:
DK Holdings Limited
Station Approach, Staplehurst
Kent TN12 0QN
UK

MINIMUM ORDER VALUE

There is no minimum order value.

DELIVERY

Phone, Fax or E- mail your order through to our sales department before 12.00pm for same day despatch on certain stocked items when you hold an approved credit account. For non account holders we will despatch on receipt of payment. Cheques and credit card/ debit payments accepted.

PAYMENT TERMS

Paying is easy. Open an account, pay by credit/debit card, cheque or credit transfer.

To qualify for credit account status, a credit application must be completed in full. Satisfactory references are required for credit consideration.

CARD PAYMENTS

We accept payment by Visa, MasterCard, Maestro and Visa Debit.

BANK DETAILS

D.K. Holdings Bank Details

International Bank Account Number (IBAN)

Bank:	National Westminster Bank PLC
Address:	3 High Street, Maidstone, Kent, ME14 1XU, United Kingdom.
Country:	GB
Currency:	STERLING
Sort PART NO.:	02901749
Account No:	06336779
IBAN No:	GB10NWBK60600802901749
B.I.C. NO:	NWBKGB2L

REMEMBER!

We are a diamond tool manufacturing company.

Four easy steps to DK manufacturing your specialist tools.

- 1 You supply a rough sketch.
- 2 We then produce a CAD drawing.
- 3 You confirm the drawing.
- 4 We manufacture your diamond tool.

Fax: +44 (0)1580 892724

DIAMOND TOOLS ALSO AVAILABLE FOR:

